

A	B	C	D
1	GR1-101	1968	400
2	GR1-102	1968	400
3	GR1-103	1968	400
4	GR1-901	1995	502
5	GR1-902	1995	392
6	GR1-201	900	400
7	GR1-202	900	400
8	GR1-301	480	400
9	GR1-302	370	400
10	GR1-303	480	400
11	GR1-304	370	400

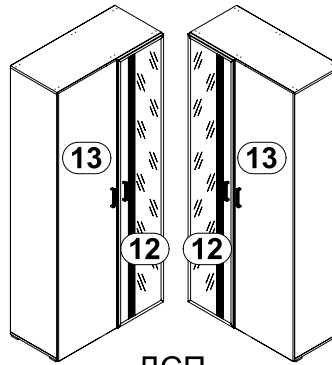

ДСП

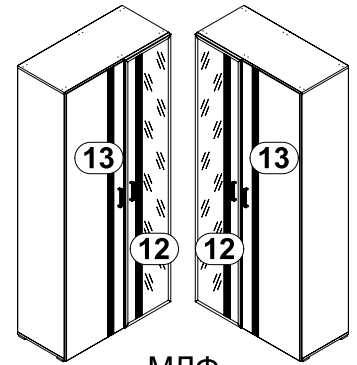

МДФ

ДСП

12	GR1-002	1996	393	3/4
13	GR1-003	1996	500	4/4

МДФ

12	GR1-002A	1996	393	3/4
13	GR1-001	1996	500	4/4

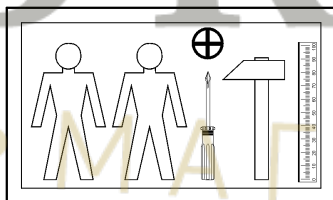
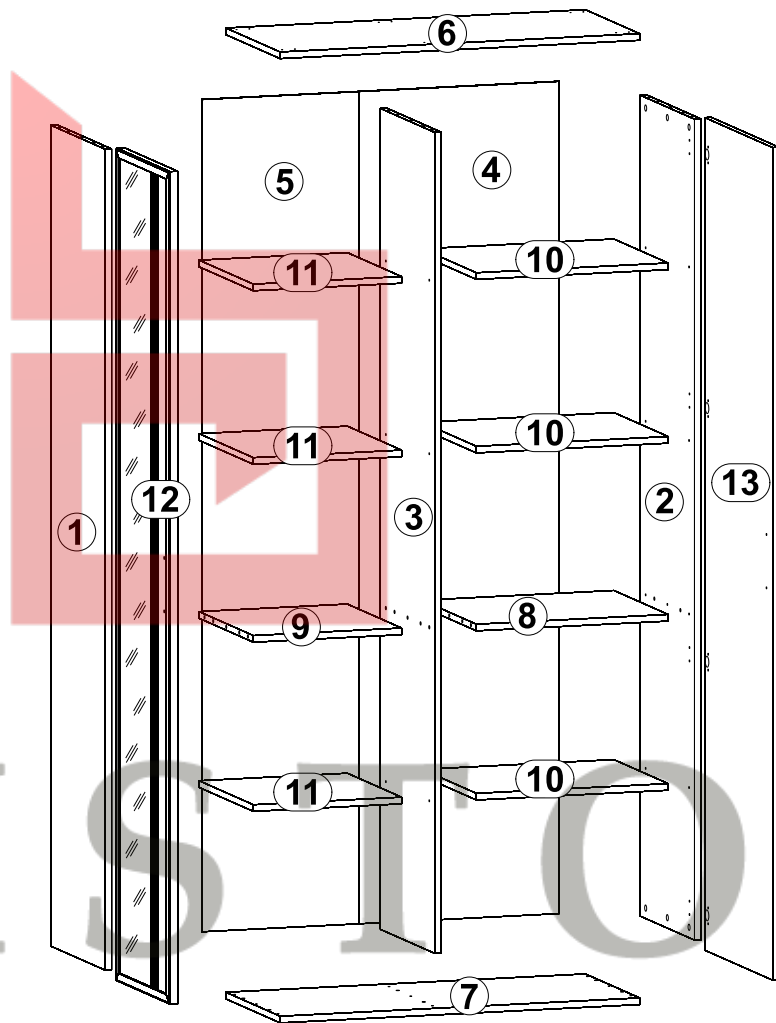
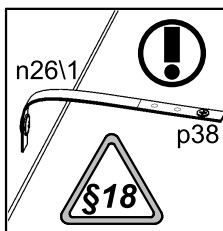
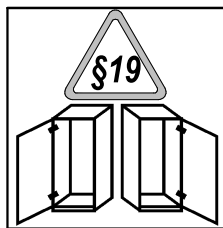

4x a2	4x a44	4x b1	4x b19	2x c406	24x d1 φ5x17 mm	16x f1 φ8x30 mm	2x f6 φ8x50 mm
2x M4x12 mm j3	2x M4x25 mm j8	6x k55	100x l1	1x n26\1	2x φ5/φ10x1.4mm o26	2x φ6.5/φ10x5.2mm o27	12x φ4x35 mm p6
1x φ3.5x16 mm p38	8x φ3.5x15 mm p51	30x φ15x12mm #16 r1	3x r10	24x 20.9 r16	30x φ16 s2		

1

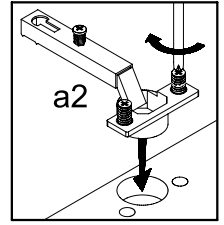
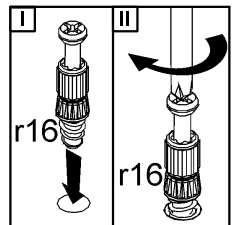
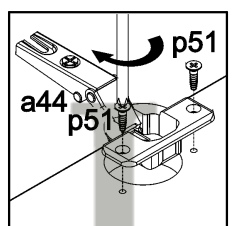
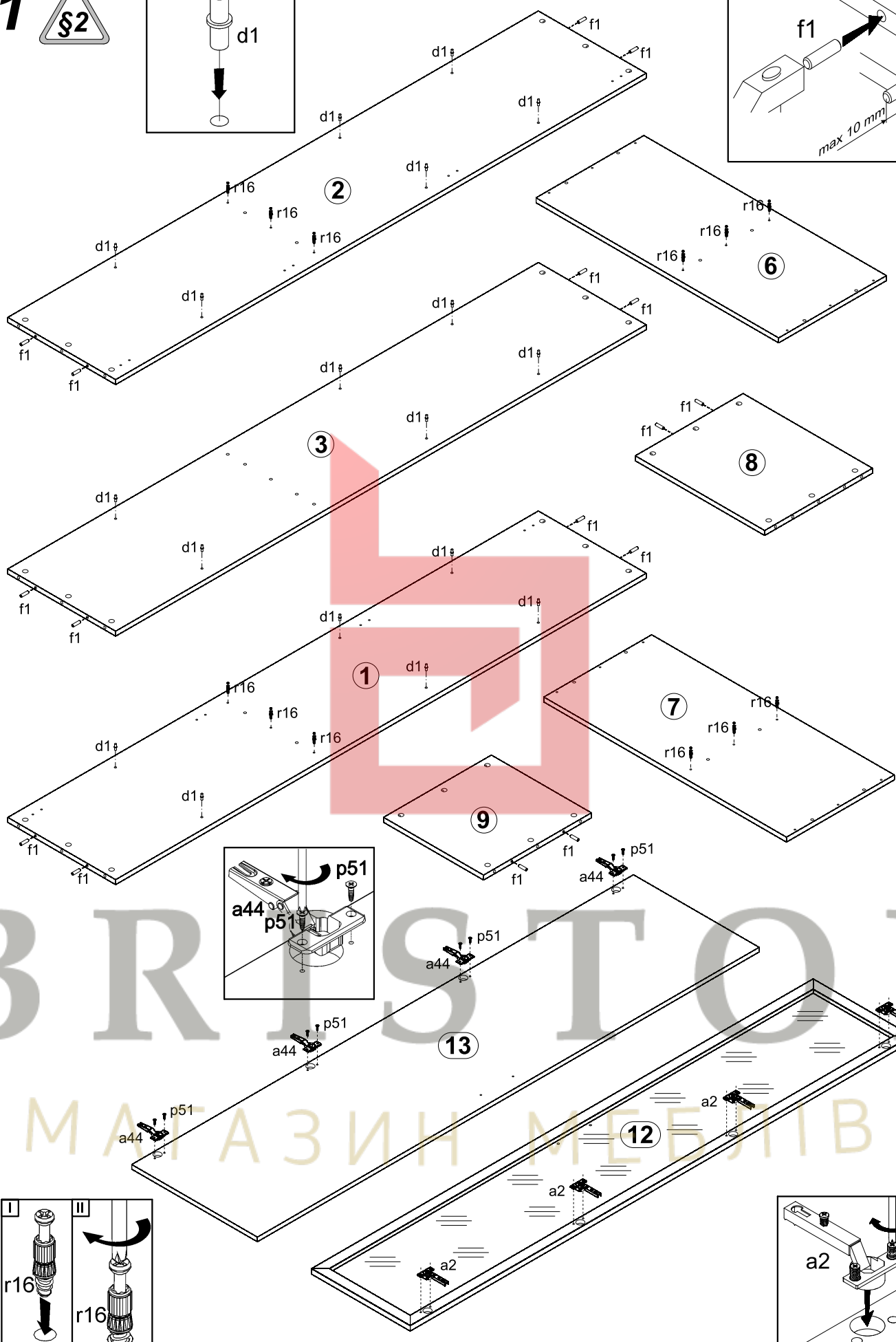
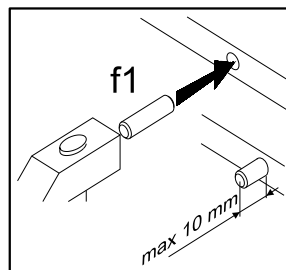
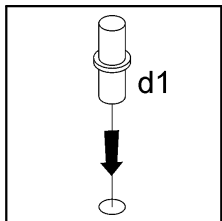

2

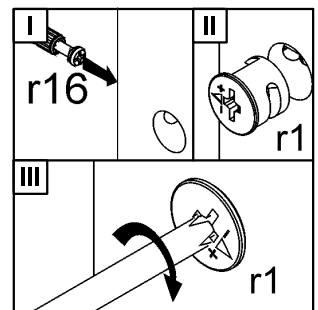
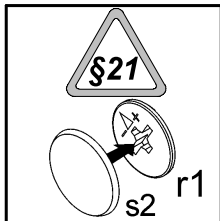
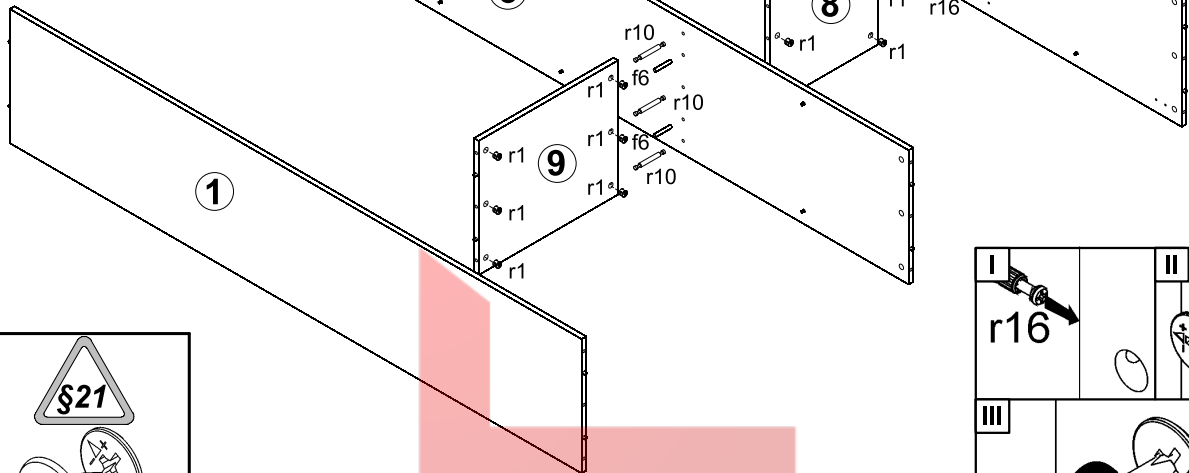
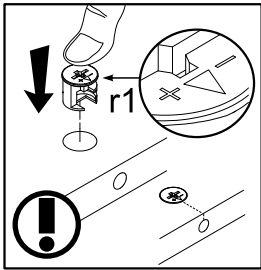

3

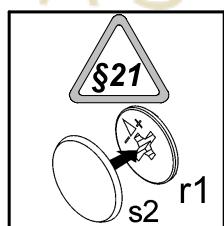
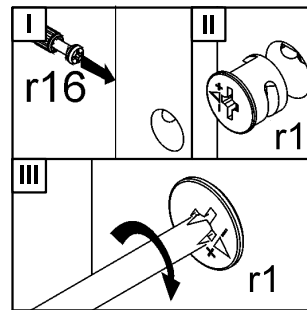
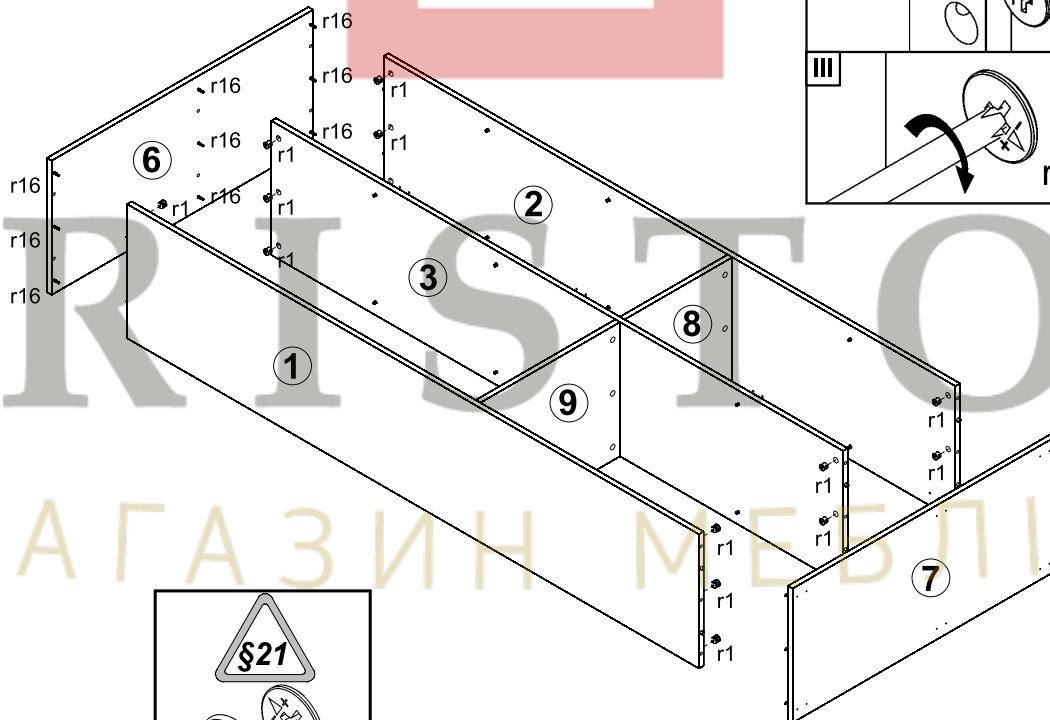

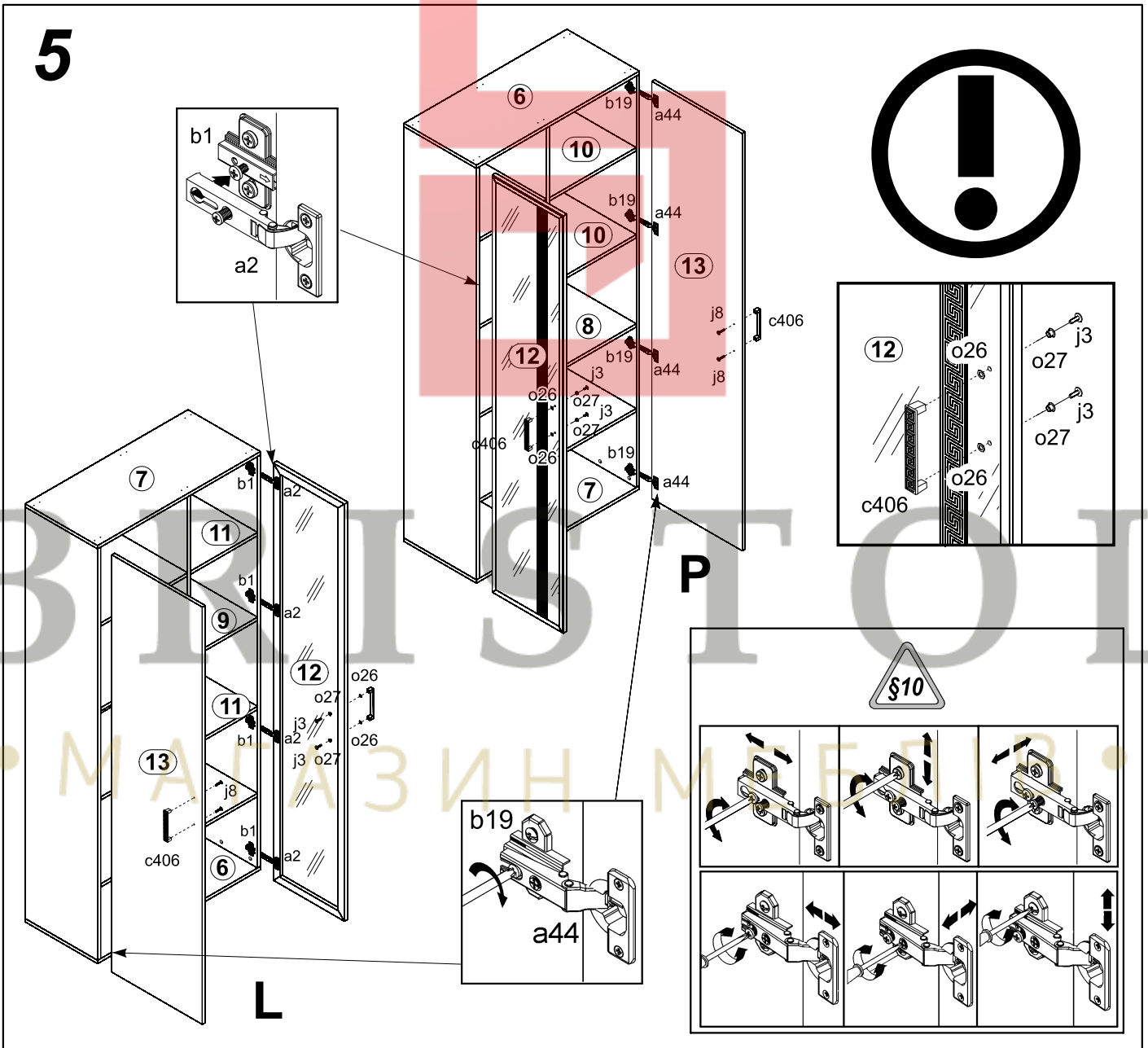
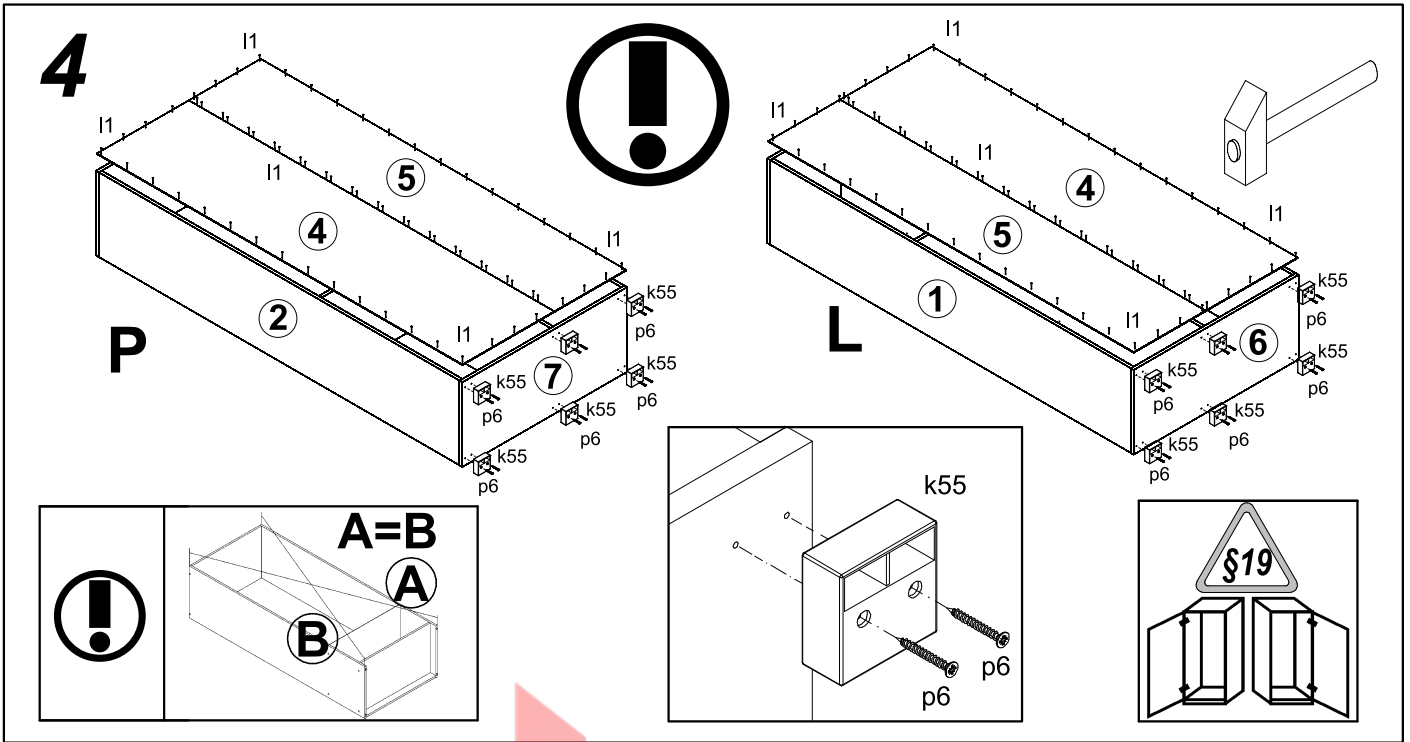

A	B	C	D	
1	GR1-104	368	500	1/2
2	GR1-105	368	500	1/2
3	GR1-106	368	500	1/2
4	GR1-203-01	1500	500	1/2
5	GR1-204	1500	500	1/2
6	GR1-305	725	500	1/2
7	GR1-502	450	120	1/2
8	GR1-503	450	120	1/2
9	GR1-504	668	120	1/2
10	GR1-904	449	683	1/2
11	GR1-903	395	747	1/2

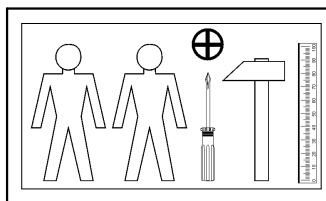

ДСП

12	GR1-006	175	746	2/2
13	GR1-007	175	746	2/2

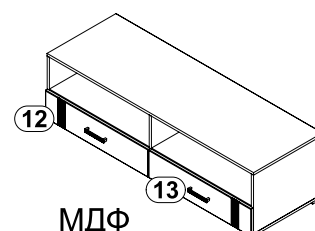
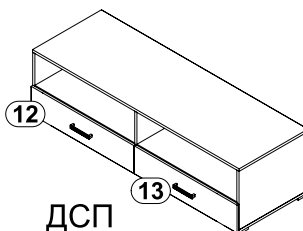

МДФ

12	GR1-004	175	746	2/2
13	GR1-005	175	746	2/2

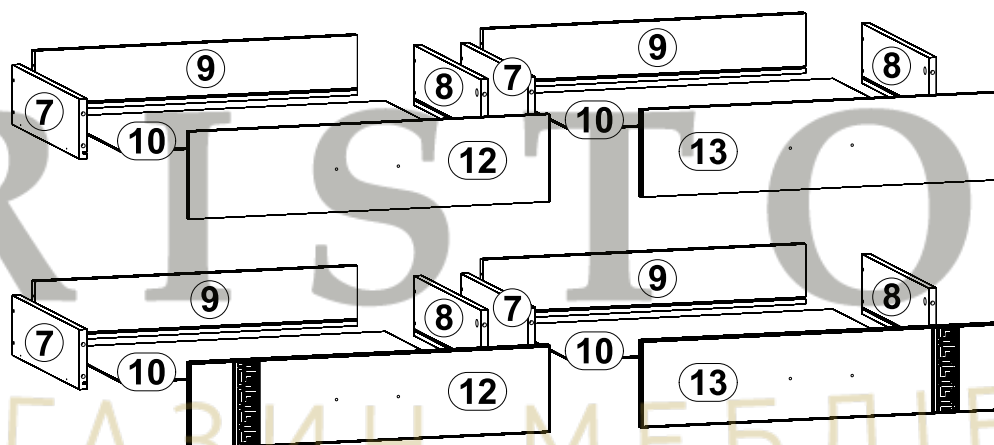
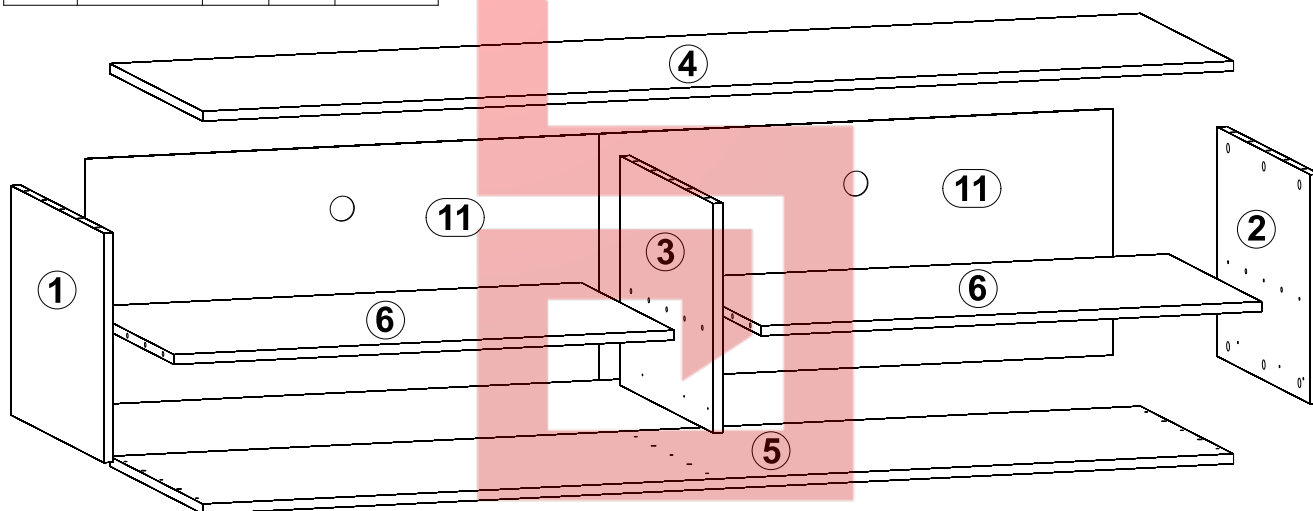

2x c406	9x φ6x13 mm e3	8x φ5x50 mm e32	16x φ8x30 mm f1	2x φ8x50 mm f6	4x M4x25 mm j8	6x k55	45x l1
3x φ3,5x13 mm p1	12x φ4x35 mm p6	4x φ3,5x16 mm p25	8x φ3x12 mm p54	38x φ15x12mm #16 r1	3x r10	32x 20/9 r16	17x φ16 s2
2x 433 mm t37	2x 450 mm w24^{DR}	2x 450 mm w24^{CR}	2x 450 mm w24^{DL}	2x 450 mm w24^{CL}	1x z1		

1

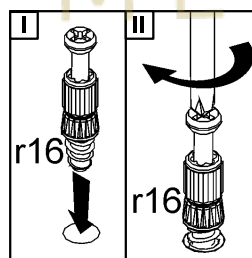
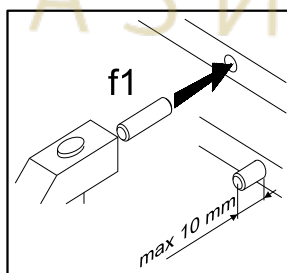
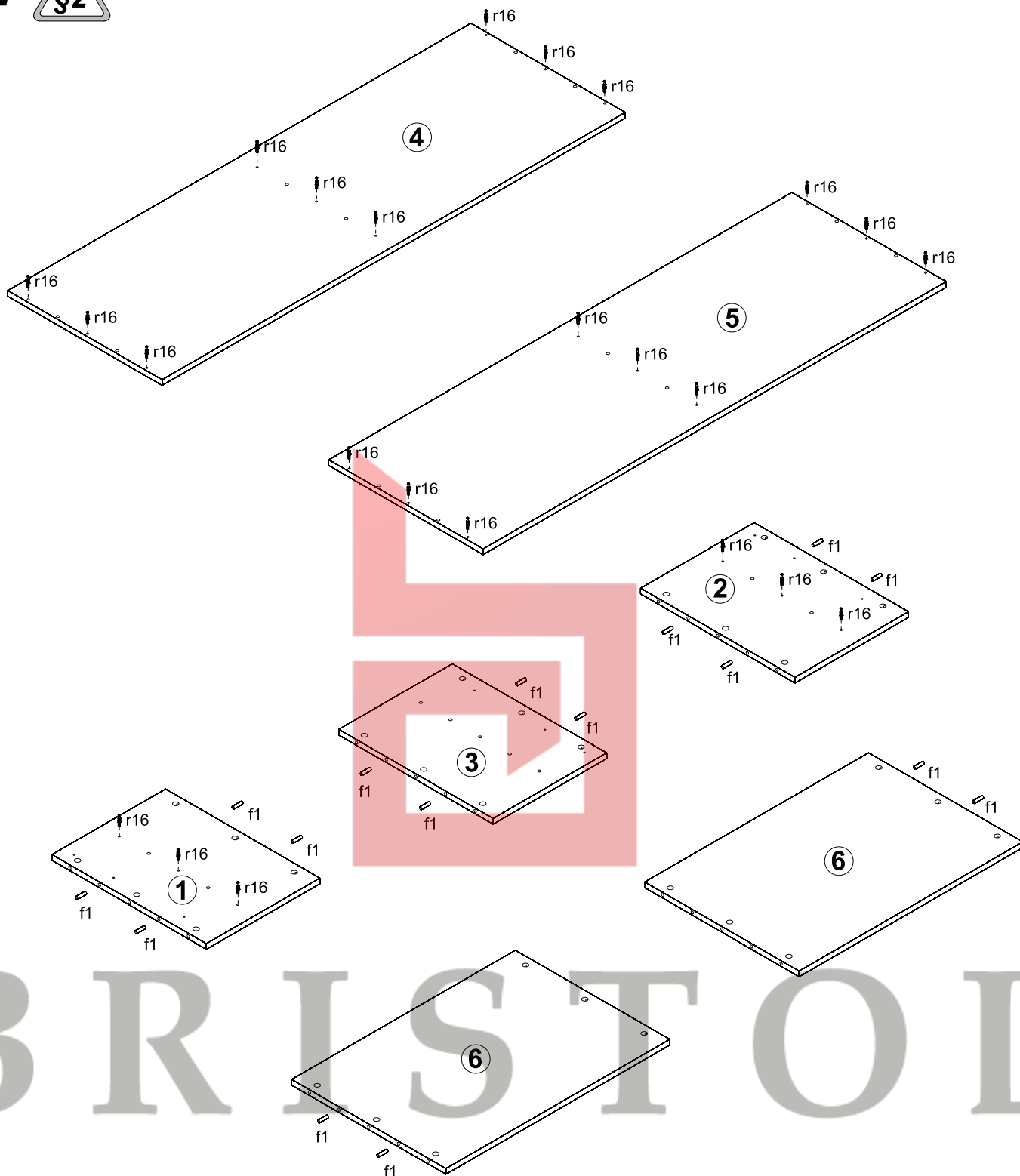

2

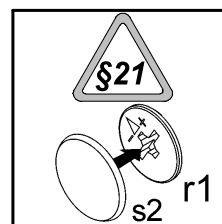
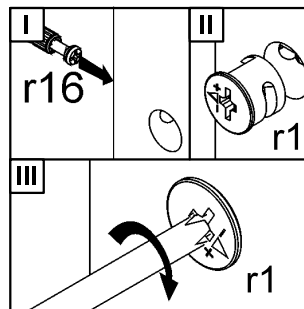
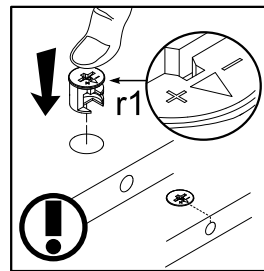
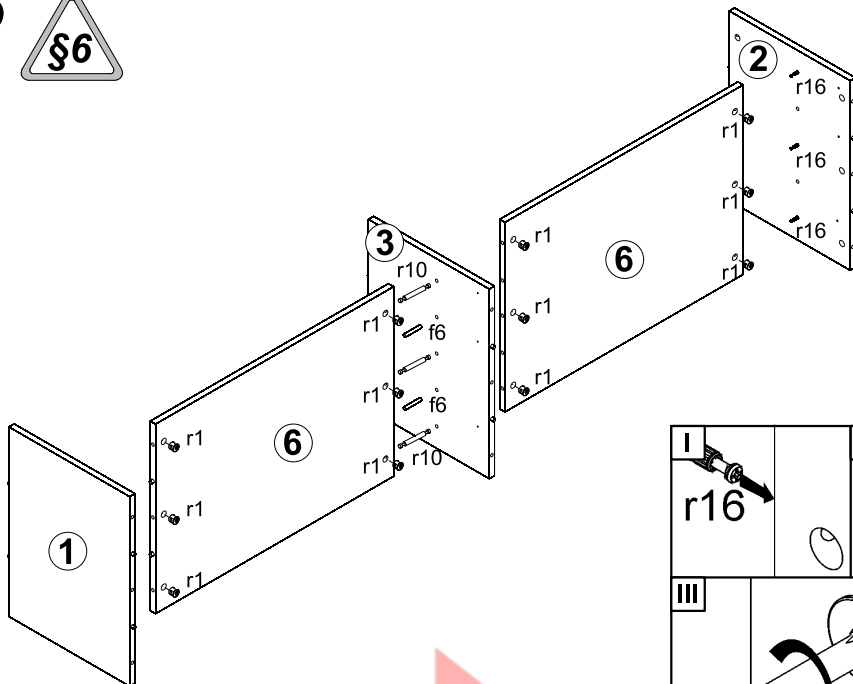

3

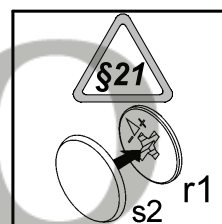
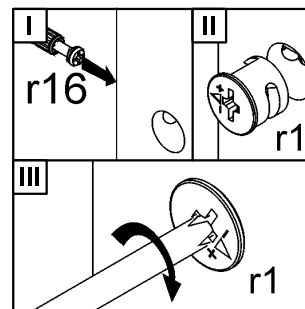
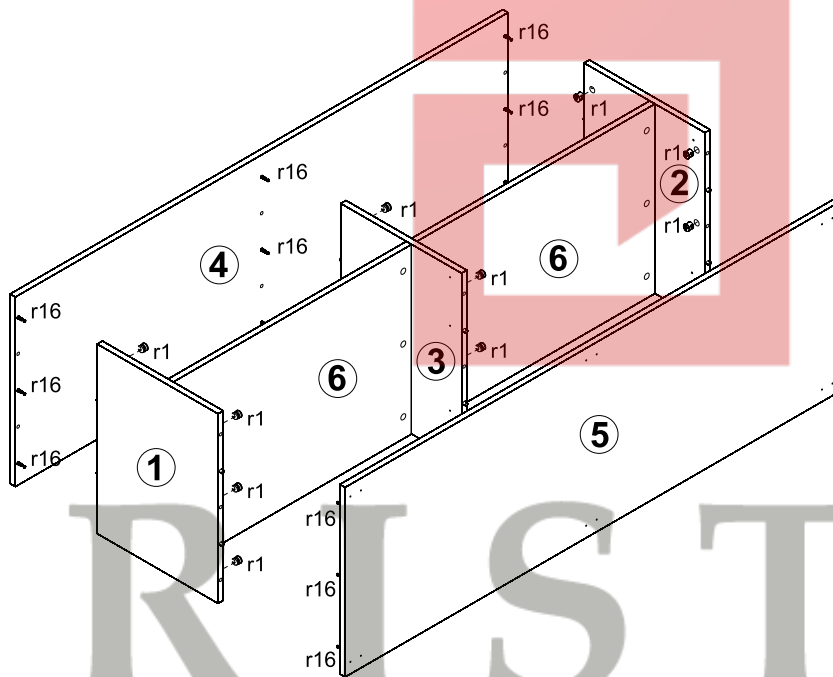

4

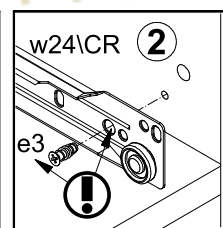
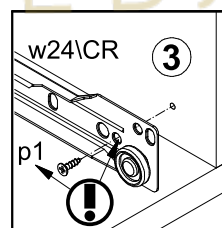
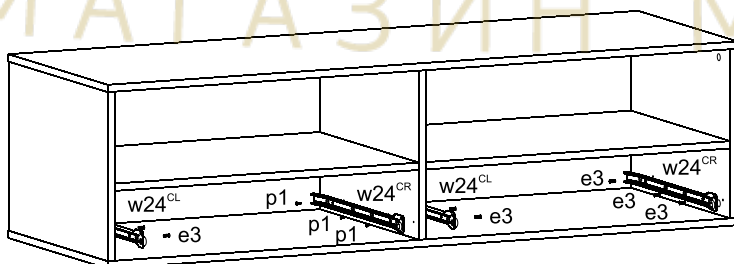

5

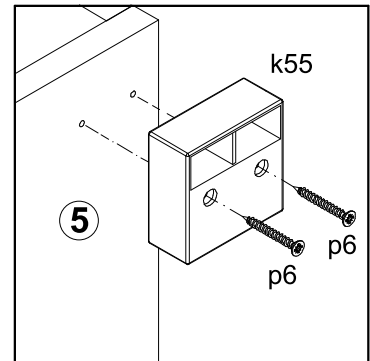
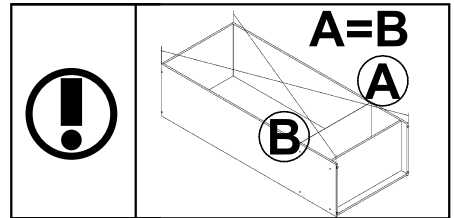
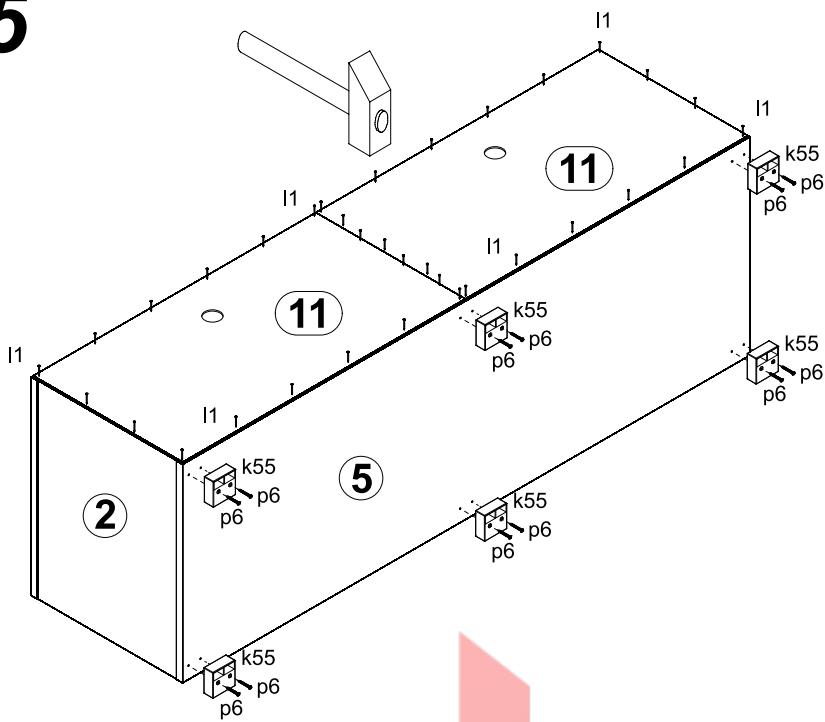

6

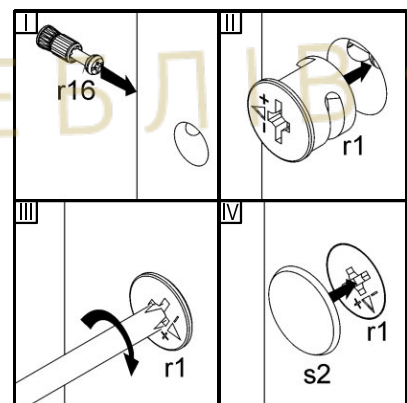
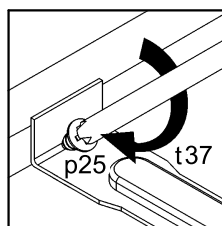
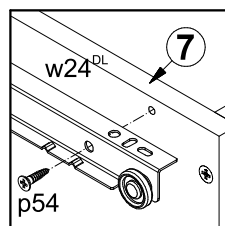
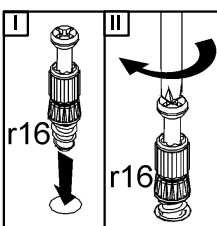
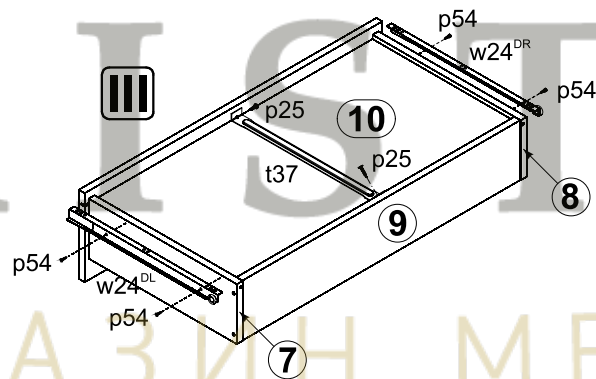
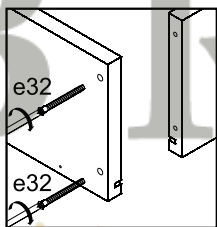
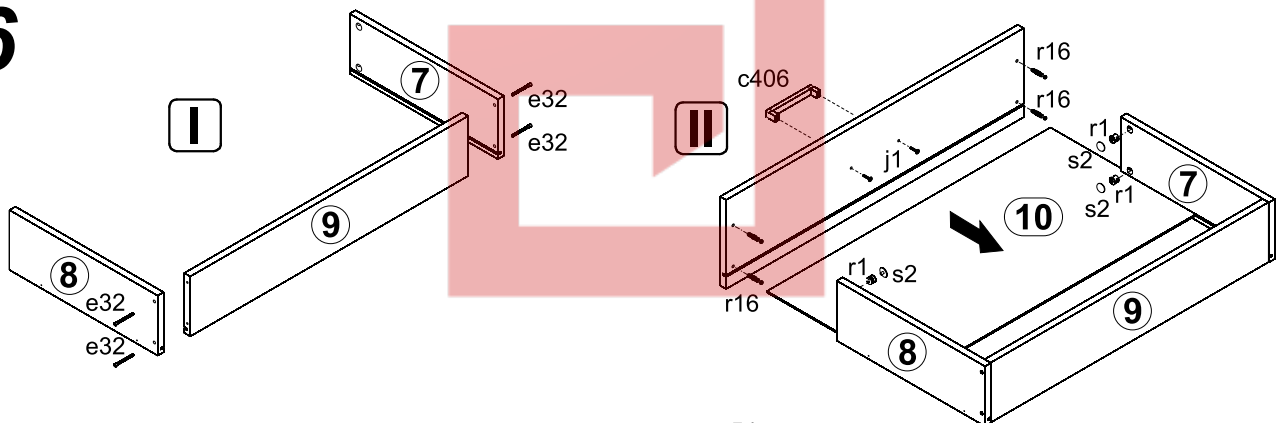

A	B	C	D
1	GR1-107	1968	400 1/4
2	GR1-108	1968	400 1/4
3	GR1-907	1995	297 1/4
4	LH-1907	1967	14 1/4
5	GR1-207	600	400 2/4
6	GR1-208	600	400 2/4
7	GR1-307	567	400 2/4
8	GR1-308	567	400 2/4

ДСП

9L	GR1-015	1205	400 3/4
9P	GR1-013	1205	596 3/4
10	GR1-014	788	596 4/4

МДФ

9L	GR1-015A	1205	400 3/4
9P	GR1-013A	1205	596 3/4
10	GR1-012	788	596 4/4

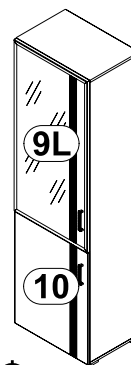
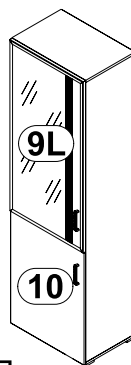

ДСП

МДФ

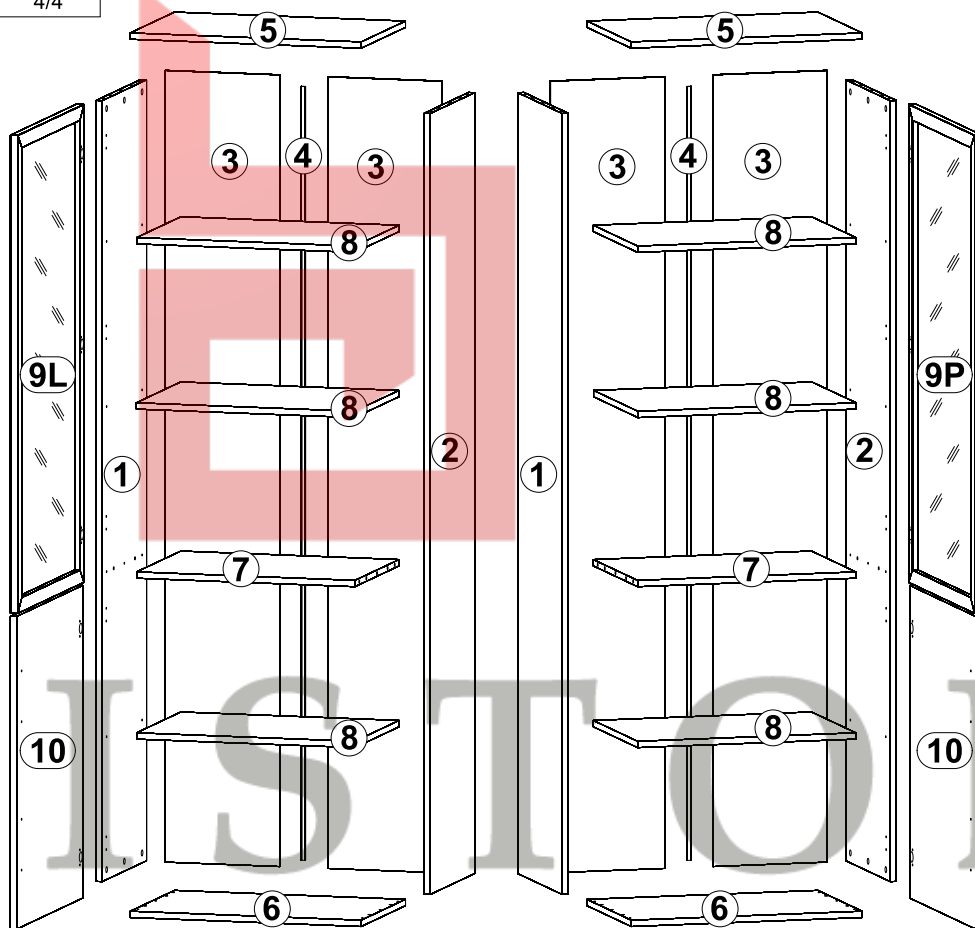
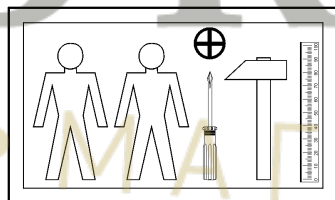
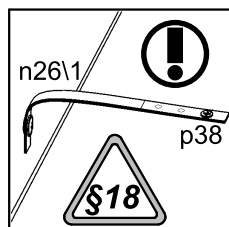
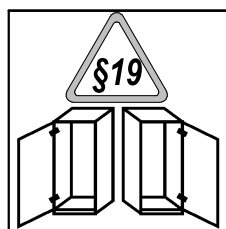

3x a2	2x a44	3x b1	2x b19	2x c406	12x d1 φ5x17 mm	12x f1 φ8x30 mm	2x j3 M4x12 mm
2x j8 M4x25 mm	4x k55	55x l1	1x n26\1	2x o26 φ5/φ10x1.4mm	2x o27 φ6.5/φ10x5.2mm	8x p6 φ4x35 mm	1x p38 ∅3.5x16 mm
4x p51 φ3.5x15 mm	18x r1 φ15x12mm #16	18x r16 20-9	18x s2 φ16	12x s4 φ5			

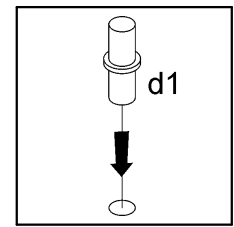
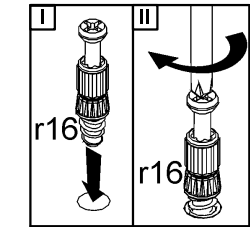
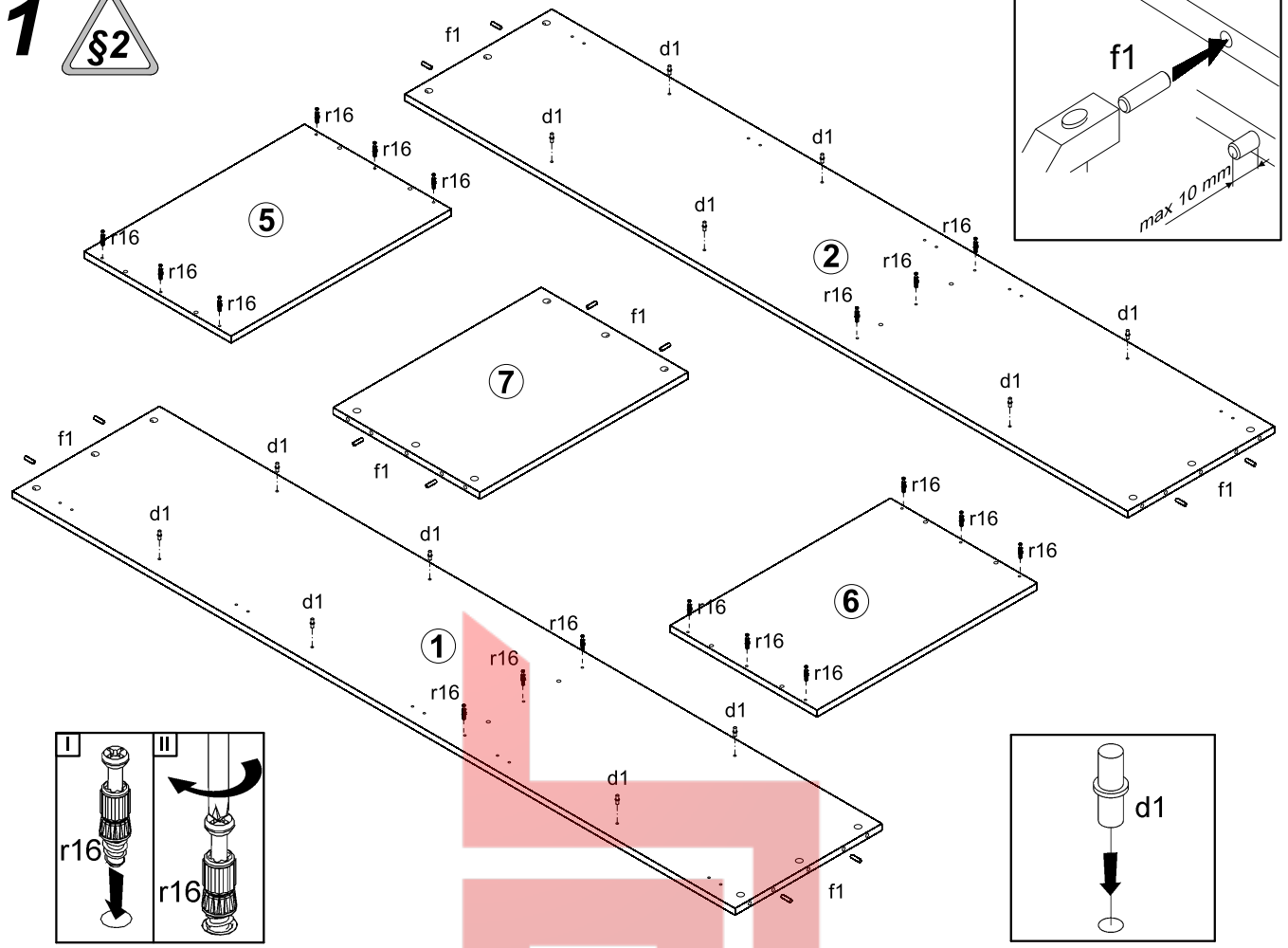
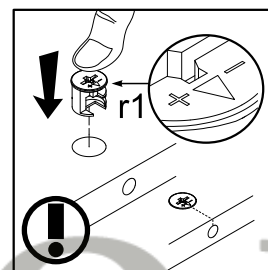
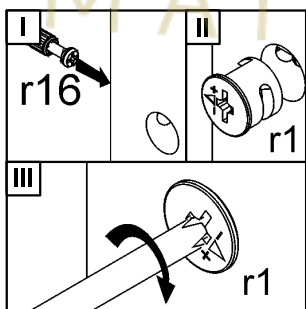
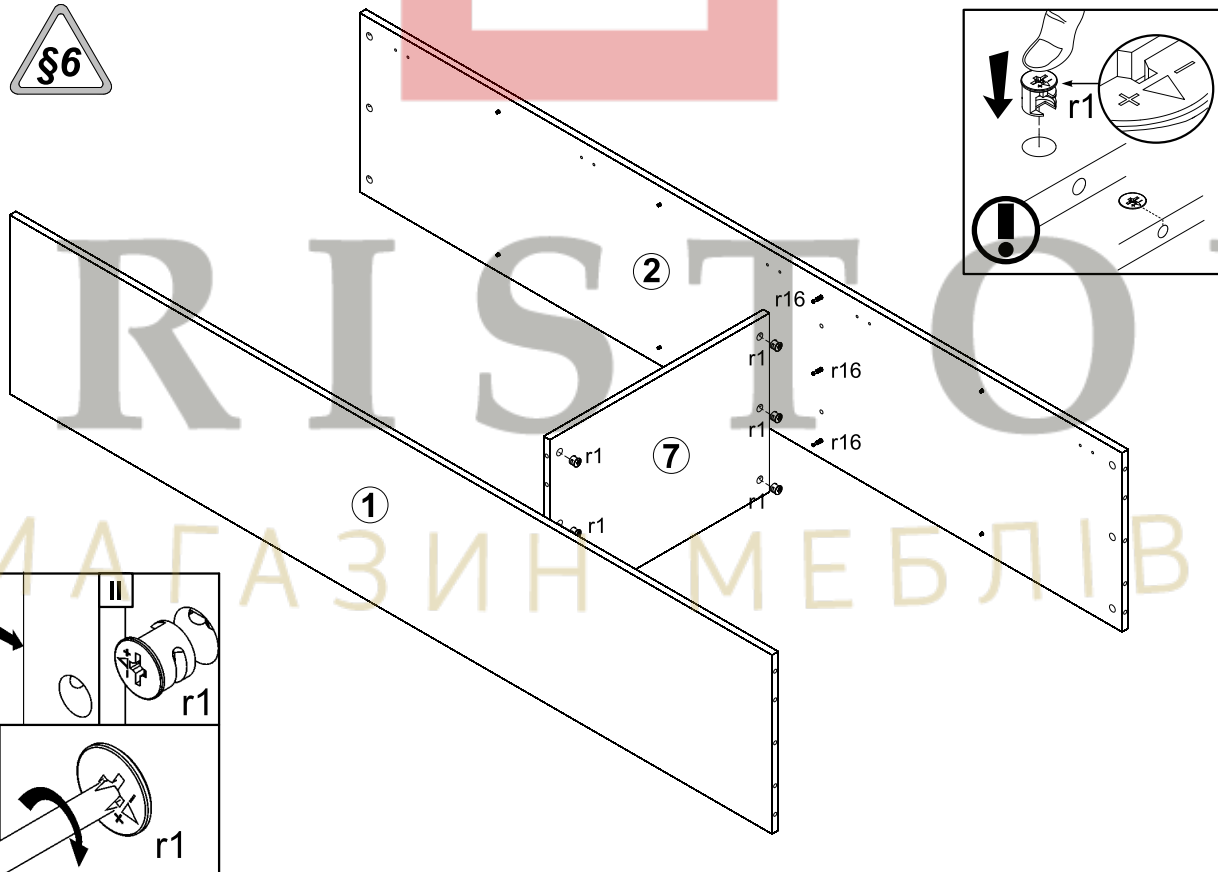
1**2**

3

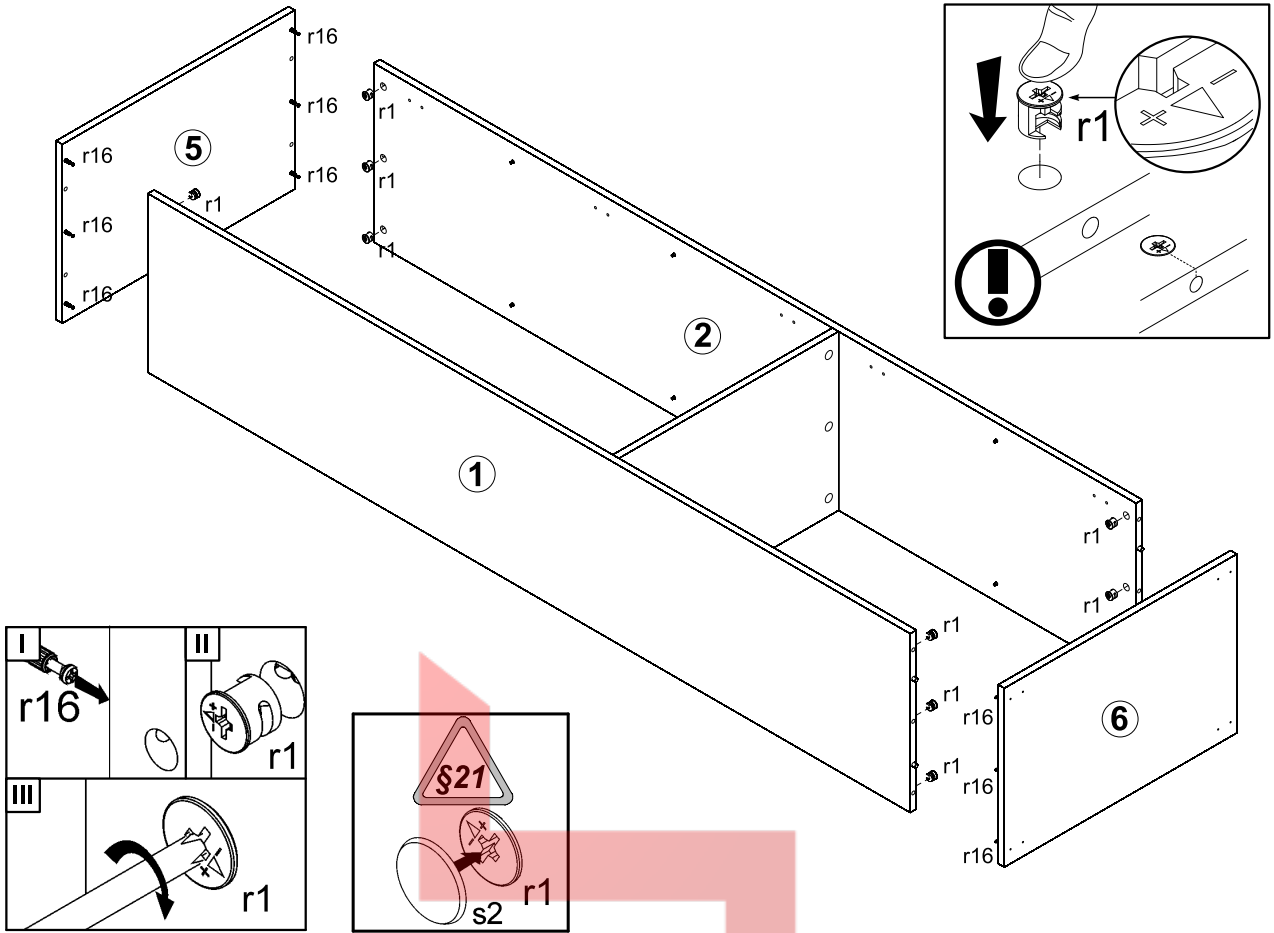

4

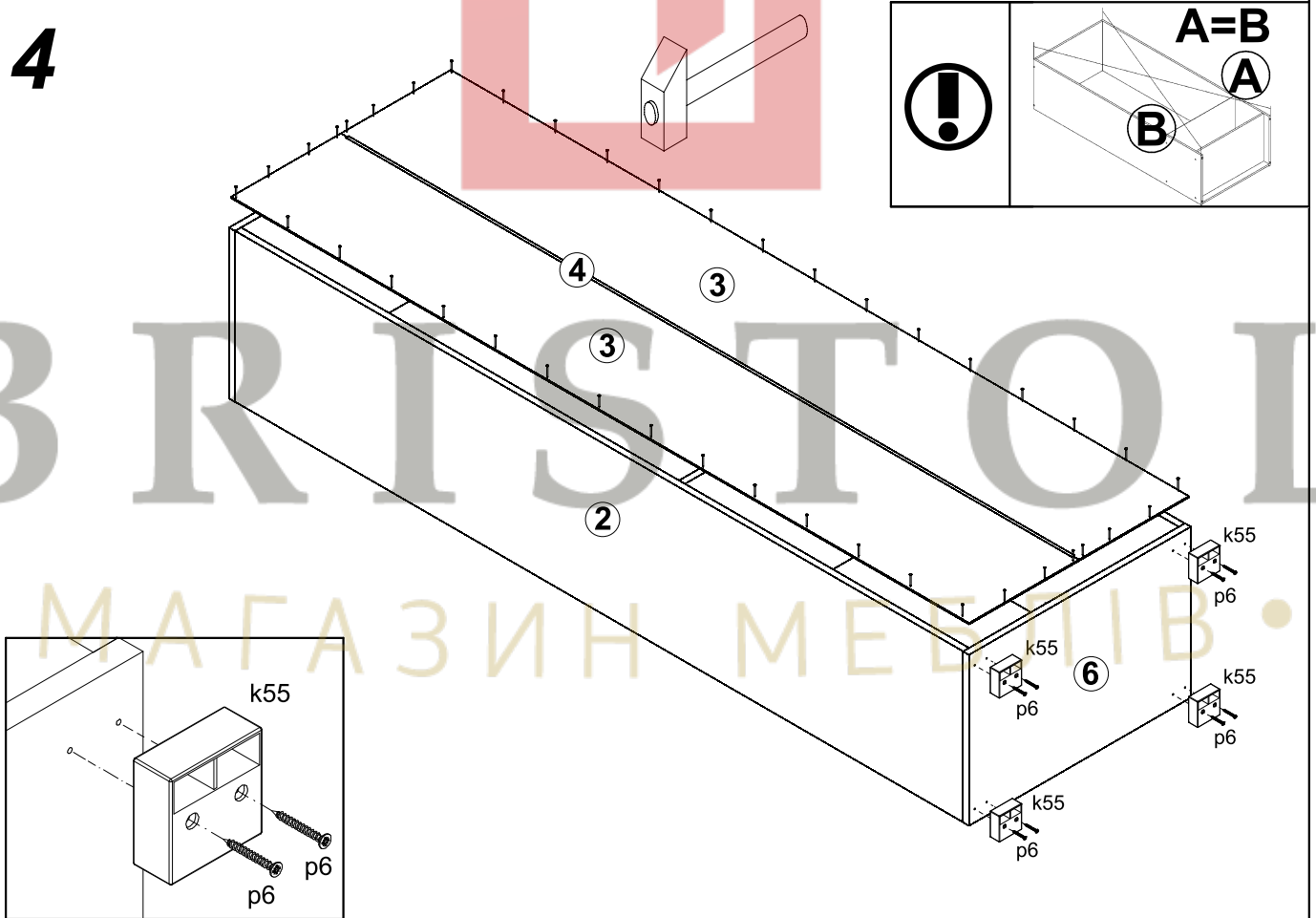

A	B	C	D
1	GR1-309	900	227 1/1
2	GR1-401	900	160 1/1

ДСП

3	GR1-402	900	80 1/1
---	---------	-----	--------

МДФ

3	GR1-403	900	80 1/1
---	---------	-----	--------

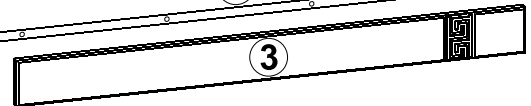
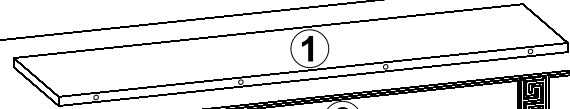
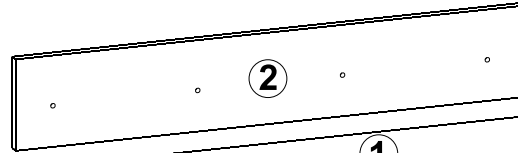
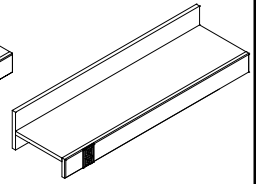
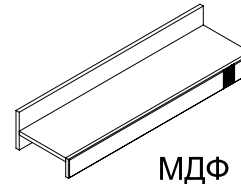
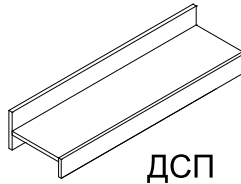
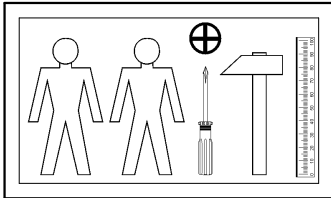

МДФ

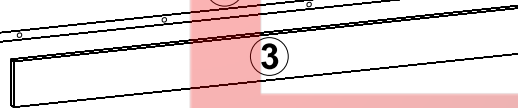
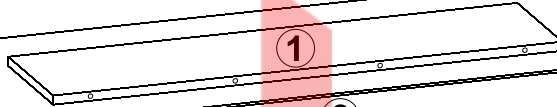
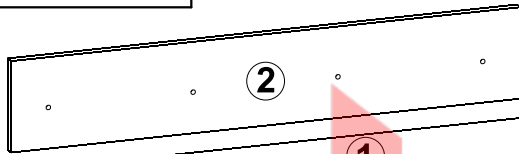

ДСП

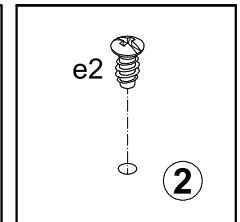
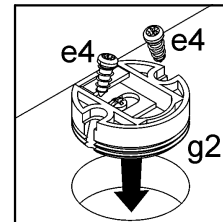
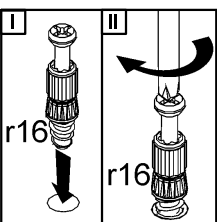
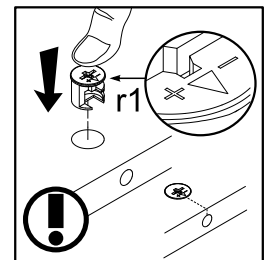
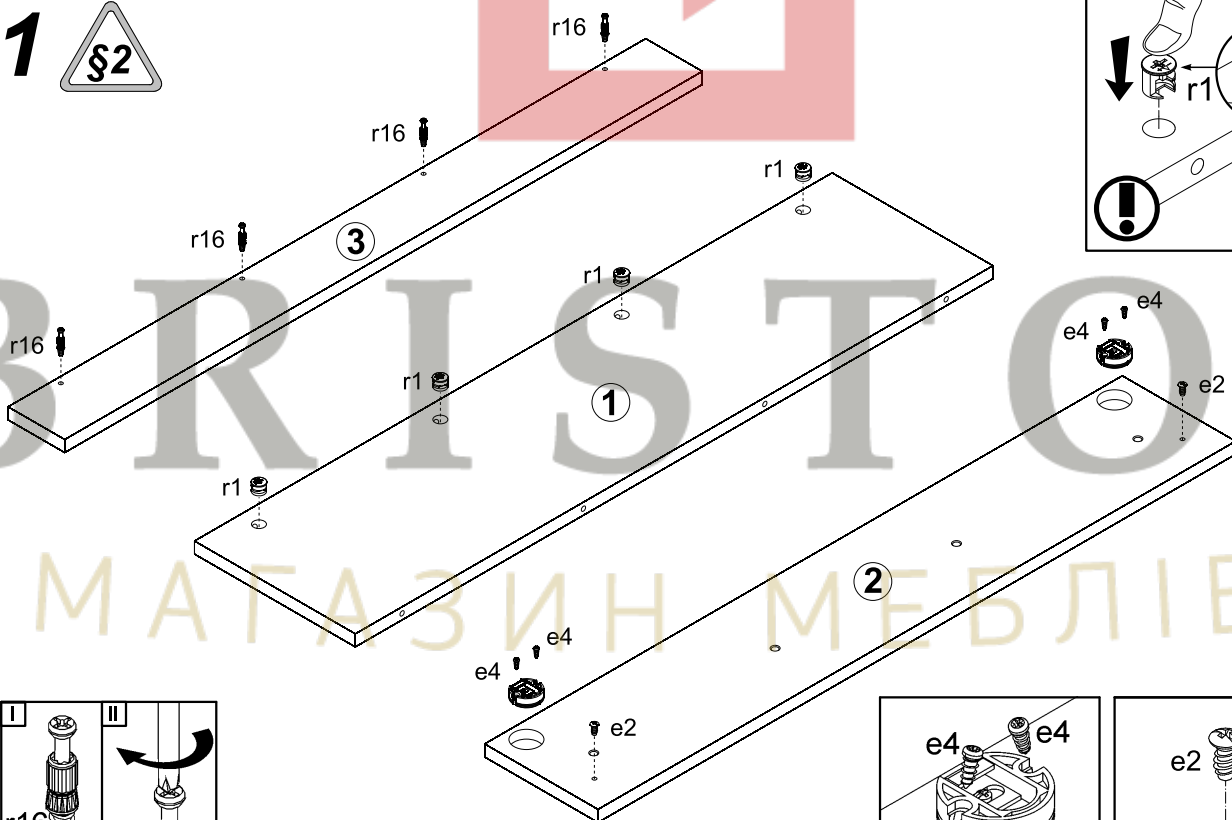
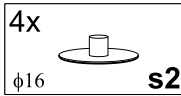
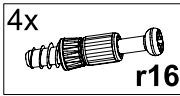
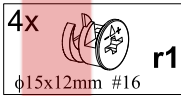
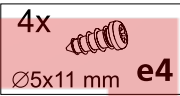
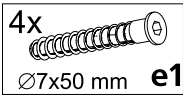

2

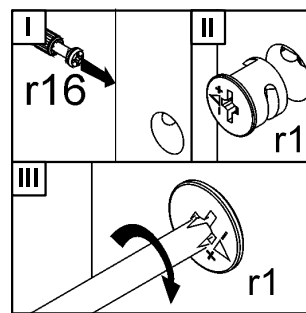
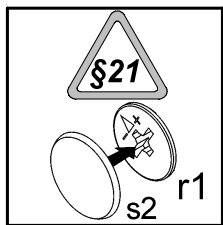
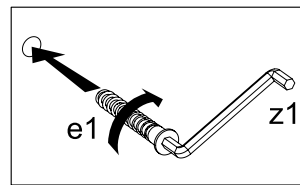
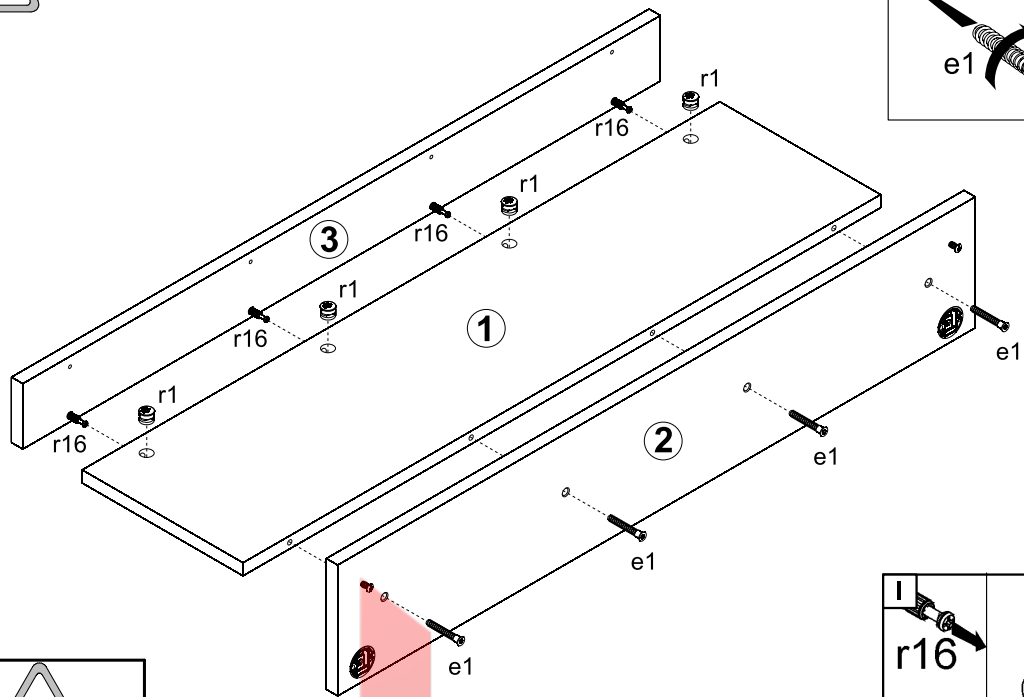

3

